



## 2/2-way valve 2W../iEA07

DN 10 to DN 50,  
self-controlled,  
positive or negative,  
for water, oil, and HFA fluid,  
with electrohydraulic pilot valve

positive - normally closed (NC)  
negative - normally open (NO)

- Rugged construction
- Use of corrosion-resistant materials for all components
- Solenoid completely separated from the flow section
- Additional facility for manual operation as standard
- No leakage loss
- Type of protection: IP 54 according to EN 60529/IEC 529
- Ex-approval: I M2 EEx ia I intrinsically safe according to Directive 94/9/EC (ATEX)

Types	Nominal width/mm	Pipe connection	Volume flow Q (l/min)*
2Wp(n)10/iEA07	10	R ⅜	80
2Wp(n)15/iEA07	15	R ½	150
2Wp(n)20/iEA07	20	R ¾	230
2Wp(n)25/iEA07	25	R 1	350
2Wp(n)32/iEA07	32	R 1¼	600
2Wp(n)40/iEA07	40	R 1½	950
2Wp(n)50/iEA07	50	R 2	1600

\* with  $\Delta p = 5$  bar



## 2W../iEA07

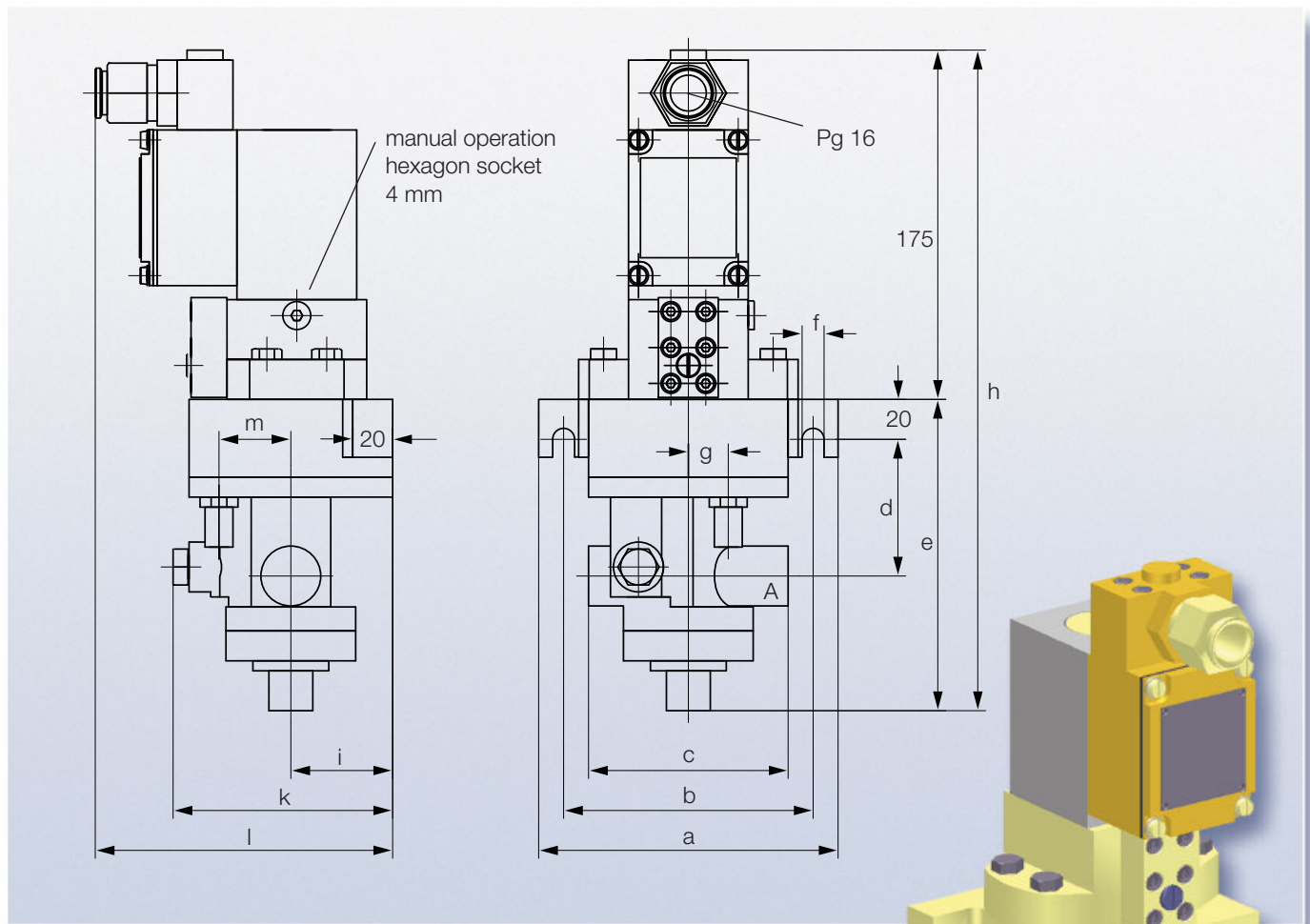

### Symbols

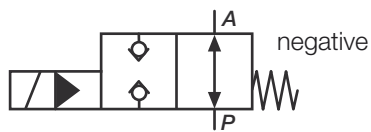
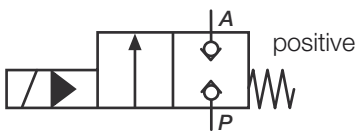

Assemb.	NW	P,A	L	a	b	c	d	e	f	g	h	i	k	l	m
1	10	R $\frac{3}{8}$	R $\frac{3}{8}$	150	125	100	68,5	156	11	20	331	51	109	156	35
1	15	R $\frac{1}{2}$	R $\frac{3}{8}$	150	125	100	68,5	156	11	20	331	51	109	156	35
2	20	R $\frac{3}{4}$	R $\frac{3}{8}$	205	176	160	95	202	13	41	377	63	133	173	40
2	25	R 1	R $\frac{3}{8}$	205	176	160	95	202	13	41	377	63	133	173	40
2	32	R $1\frac{1}{4}$	R $\frac{3}{8}$	205	176	160	95	202	13	41	377	63	133	173	40
3	40	R $1\frac{1}{2}$	R $\frac{3}{8}$	205	176	170	107	244	13	41	419	63	133	173	45
3	50	R 2	R $\frac{3}{8}$	205	176	170	107	244	13	41	419	63	133	173	45



## 2W../iEA07

### FUNCTION UND DESIGN

In fluid technology, directional control valves are designed to allow passage of the operating medium (compressed air or hydraulic fluid), to block passage or to change the direction of flow. The designation of the directional control valve is derived from the number of switching positions as well as the number of ports per switching position.

The 2/2-way valve is a pilot-operated seating-action valve with two ports and two switching positions. It consists of the main control unit with a disk-shaped seating piston and the pilot control unit. The pilot control unit consists of a ball seat valve activated via an intrinsically safe valve solenoid. Seating-action valves have the advantage over spool valves in that no leakage losses occur.

The 2/2-way valve is self-controlled. That means, for operating the pilot control unit the working medium from the main control unit is utilized. Bore ducts are provided allowing the compressed air to pass between the two units. In order to protect the pilot control unit from impurities the duct for the pressure supply has a filter installed which can be replaced easily and quickly. In rest position, the main control unit is closed at the return pressure side P. When the pilot control unit is actuated via the valve solenoid the main control unit is operated hydraulically allowing flow from the pressure side P to the working side A.

Leakage port L is designed to ventilate space E when changing switching positions. The fluid quantity discharged is small and can be returned to the tank.

The valve housing is made of red brass and all further mounting parts of the valve are also made of corrosion-resistant materials. The components of the solenoid are largely embedded in cast resin. The overall design of the valve ensures safety with respect to explosion protection and mechanical damage.

The 2/2-way valve is noted for a long service life. It has proved its worth for decades even in the adverse conditions of underground mining.

### Sequence of functions for the "positive" design

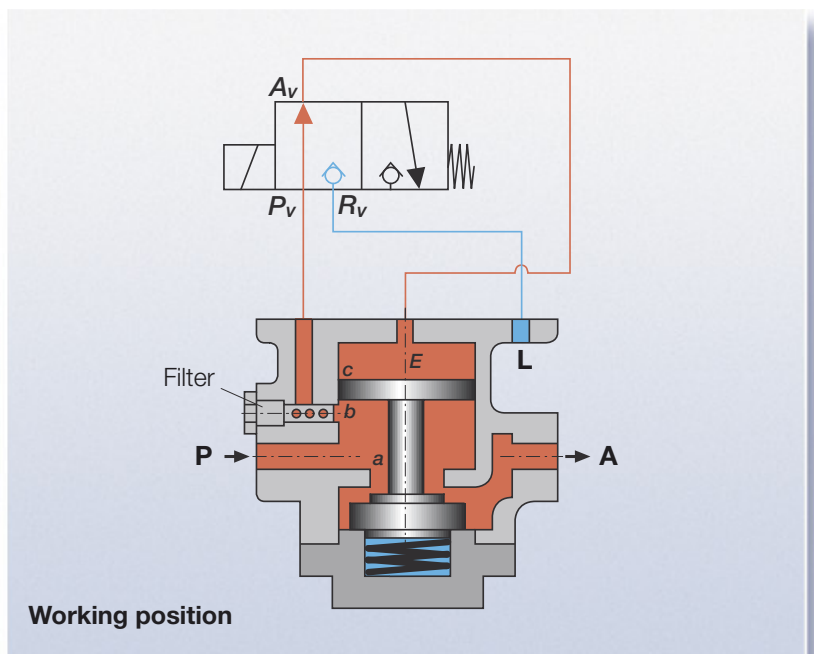
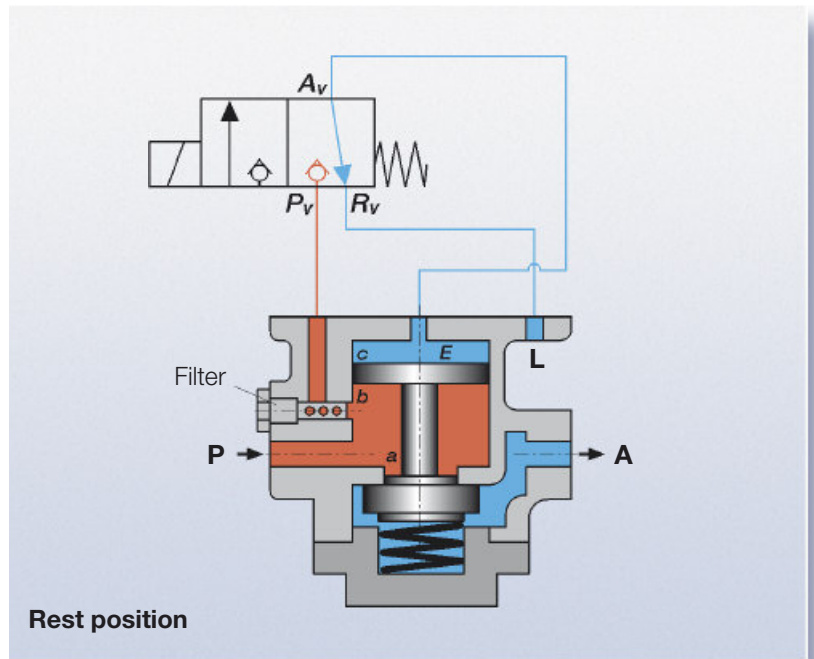

- For the „negative“ design the pilot valve in rest position is opened and closed in working position.



## 2W../iEA07

### TECHNICAL DATA

Type	pilot-operated 2-way valve
Housing/flow part	gunmetal
Valve seat sealing	flexible seal on metal
Ports	pipe thread R $\frac{1}{2}$ – R2
Medium	water, oil, HFA fluid
Temperature of medium	max. 85 °C
Operating pressure	3 bar – 40 bar
Electr. connection	intrinsically safe d.c. voltage, polarity reversible
Electr. connection values	V <sub>nom</sub> = 12 V DC; V <sub>max</sub> = 13.5 V DC; I <sub>nom</sub> = 220 mA
Temperature range	-20 °C to 60 °C
Type of protection	IP 54 according to EN 60529/IEC 529
Ex-approval	I M2 EEx ia I acc. to Directive 94/9/EC (ATEX)
Certificate number	DMT 99 ATEX E 102

### TYPE CODE AND ORDERING INFORMATION

<b>2W ** / iEA07</b>	Valve solenoid, intrinsically safe
	Nominal width in mm
	p = positive; n = negative
	2/2-way valve for water, oil and HFA fluid

### TYPICAL EXAMPLE

<b>2Wp25/iEA07</b>	<ul style="list-style-type: none"> <li>■ 2/2-way valve</li> <li>■ Design positiv</li> <li>■ Nominal width 25 mm</li> </ul>	<ul style="list-style-type: none"> <li>■ With intrinsically safe solenoid for water, oil and HFA fluid</li> </ul>
--------------------	--	---

Subject to technical alterations · Version 09/12